

BROADWAY™ SCATTER BLOCKS™

12" x 12"
(305mm x 305mm)

Broadway Scatter Blocks present an 'easy to install' solution for acoustic treatment where you want to control sound, but do not want to eliminate the natural ambiance. Scatter Blocks are designed to be randomly spaced on large wall surfaces to create an effect we call Soft Diffusion™ - an affordable alternative to full scale quadratic diffusion. By leaving reflective spaces in between the panels, some energy is absorbed while some is left to reflect back into the room. This helps control flutter echo and reduces standing waves while leaving a sense of 'air' or space in the room. Broadway Scatter Blocks come in choice of 2 thicknesses and 3 colors

SPECIFICATIONS:

DIMENSIONS	12" x 12" (305mm x 305mm)
PANEL DEPTH	1" (25mm), 2" (51mm)
CORE MATERIAL DENSITY	Formed, semirigid inorganic glass fibers, 6.0 lbs pcf (96 kg/m3)
FABRIC FACING	Acoustically transparent polyester
BACKING	Sealed with acoustically transparent micro-mesh
EDGE TREATMENT	Sealed and hardened with resin

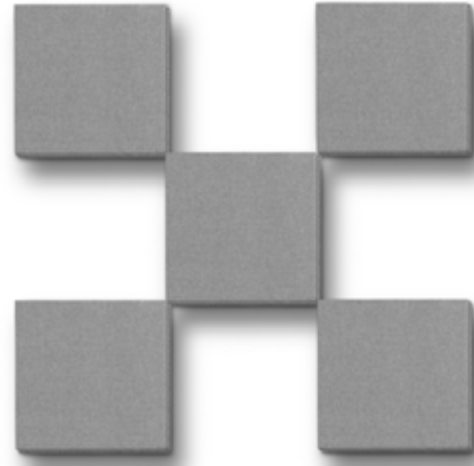

ABSORPTION CHARACTERISTICS:*

Sound absorption data (NRC values) ASTM C423-90a.

Panel Depth	125Hz	250Hz	500Hz	1kHz	2kHz	4kHz	NRC
1" Depth	0.17	0.28	0.81	1.00	1.02	0.95	0.80
2" Depth	0.45	0.83	1.07	1.00	1.01	1.00	1.00

* Testing performed by Riverbank Acoustical Laboratories. The test method conformed explicitly with the requirements of the ASTM Standard Test Method for Sound Absorption and Sound Absorption Coefficients by the Reverberation Room Method: ASTM C 423-02a and E795-05.

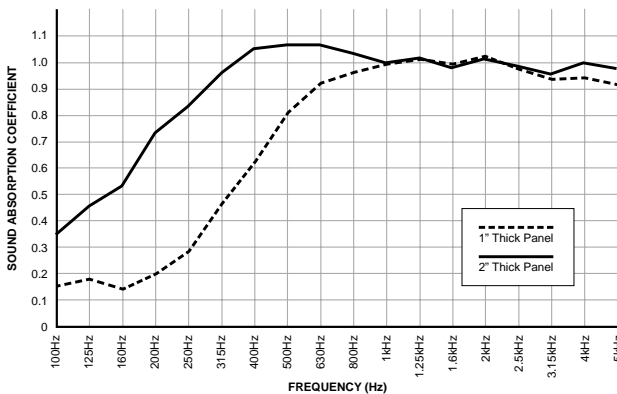

APPLICATION:

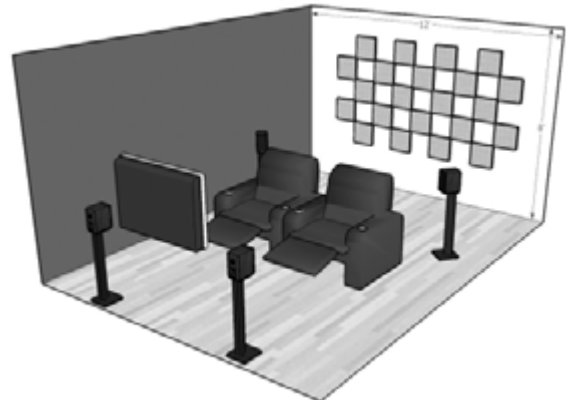

PRODUCT RANGE:

ORDER NO.	COLOR	DEPTH	EDGE	COVERAGE	BOX QTY.
F101-1212-00	Black	1" (25mm)	Square	24 sq/ft (2.23sq/m)	24
F101-1212-03	Beige				
F101-1212-08	Grey				
F102-1212-00	Black	2" (51mm)	Square	24 sq/ft (2.23sq/m)	24
F102-1212-03	Beige				
F102-1212-08	Grey				

FIRE & BURN PERFORMANCE:**

TEST	CLASS	FLAME SPREAD	SMOKE DENSITY
ASTM E 84-05	1 OR A	15 FSI	155 SD
CAN/UL-S102	1 OR A	15 FSC1	155 SD

** Test data provided by Bodycote Materials Testing Inc. This method, designated as ASTM E 84-05, "Standard Method of Test for Surface Burning Characteristics of Building Materials", is used to measure and describe the response of materials, products, or assemblies to heat and flame under controlled conditions, but does not by itself incorporate all factors required for fire-hazard or fire-risk assessment of the materials, products, or assemblies under actual fire condition.

MOUNTING OPTIONS:

SURFACE IMPALER	OFF-SET IMPALER	CORNER IMPALER
F101-1000-00	F101-1001-00	F101-1002-00
24 per box	8 per box	8 per box

BROADWAY™ CONTROL COLUMNS™

 12" x 48"
(305mm x 1219mm)

Control Columns are designed to be positioned in arrays to treat bothersome reflections that exist between the sound source and the listener. The panels are typically spread across a wall surface leaving reflective space in between each panel so as not to completely deaden the space. This helps control acoustic reflections while leaving a sense of 'air' or natural ambiance. The Control Column's long narrow design is reminiscent of the historic 'Roman Pillar' making it an ideal compliment the most demanding architectural designs. Control Columns are an excellent choice in live-end, dead-end studio designs and home theatres while also providing a cost effective alternative for larger spaces such as music practice rooms, dance studios, fitness centers and classrooms. Broadway Control Columns come in a choice of 3 thicknesses and 3 colors and may be ordered with or without a beveled edge.

SPECIFICATIONS:

DIMENSIONS	12" x 48" (305mm x 1219mm)
PANEL DEPTH	1" (25mm), 2" (51mm), 3" (76mm)
CORE MATERIAL DENSITY	Formed, semirigid inorganic glass fibers, 6.0 lbs pcf (96 kg/m ³)
FABRIC FACING	Acoustically transparent polyester
BACKING	Sealed with acoustically transparent micro-mesh
EDGE TREATMENT	Sealed and hardened with resin

ABSORPTION CHARACTERISTICS:*

PANEL DEPTH	125Hz	250Hz	500Hz	1kHz	2kHz	4kHz	NRC
1" Depth	0.17	0.28	0.81	1.00	1.02	0.95	0.80
2" Depth	0.45	0.83	1.07	1.00	1.01	1.00	1.00
3" Depth	0.92	0.91	1.00	1.00	1.02	1.03	1.00

* Testing performed by Riverbank Acoustical Laboratories. The test method conformed explicitly with the requirements of the ASTM Standard Test Method for Sound Absorption and Sound Absorption Coefficients by the Reverberation Room Method: ASTM C 423-02 and E795-05.

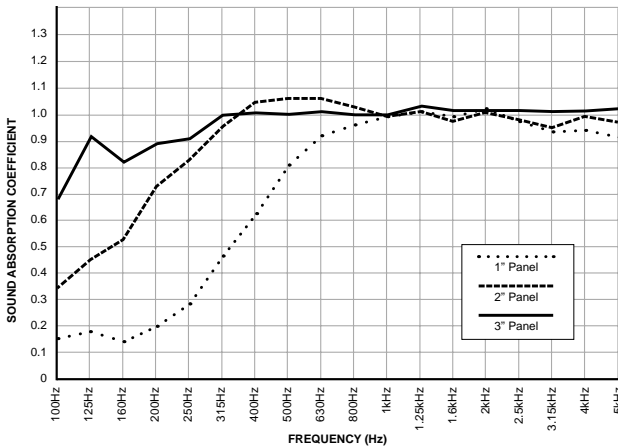
FIRE & BURN PERFORMANCE:**

TEST	CLASS	FLAME SPREAD	SMOKE DENSITY
ASTM E 84-05	1 OR A	15 FSI	155 SD
CAN/UL-S102	1 OR A	15 FSC1	155 SD

** Test data provided by Bocyote Materials Testing Inc. This method, designated as ASTM E 84-05, "Standard Method of Test for Surface Burning Characteristics of Building Materials", is used to measure and describe the response of materials, products, or assemblies to heat and flame under controlled conditions, but does not by itself incorporate all factors required for fire-hazard or fire-risk assessment of the materials, products, or assemblies under actual fire condition.

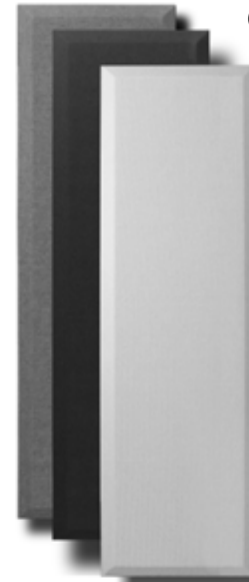
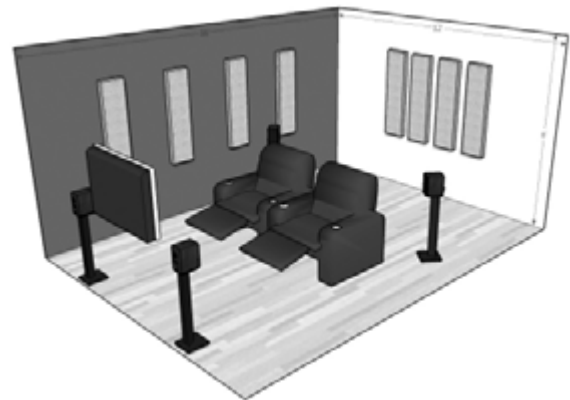
APPLICATION:

PRODUCT RANGE:

ORDER NO.	COLOR	DEPTH	EDGE	COVERAGE	BOX QTY.
F101-1248-00	Black	1" (25mm)	Square	48 sq/ft (4.46 sq/m)	12
F101-1248-03	Beige				
F101-1248-08	Grey				
F102-1248-00	Black	2" (51mm)	Square	48 sq/ft (4.46 sq/m)	12
F102-1248-03	Beige				
F102-1248-08	Grey				
F122-1248-00	Black	2" (51mm)	Beveled	48 sq/ft (4.46 sq/m)	12
F122-1248-03	Beige				
F122-1248-08	Grey				
F103-1248-00	Black	3" (76mm)	Square	32 sq/ft (2.97 sq/m)	8
F103-1248-03	Beige				
F103-1248-08	Grey				

MOUNTING OPTIONS:

SURFACE IMPALER	OFF-SET IMPALER	CORNER IMPALER
F101-1000-00	F101-1001-00	F101-1002-00
24 per box	8 per box	8 per box

BROADWAY™ CONTROL CUBES™

24" x 24"
(610mm x 610mm)

Broadway Control Cubes present an attractive, 'easy to install' solution for acoustic treatment where you want to control primary reflections, eliminate flutter echo and reduce standing waves. The panels are typically spaced in an array leaving some reflective space between panels so as not to completely deaden the room. This helps control acoustic problems while leaving a sense of 'air' or space in the room. The Control Cube's square design is particularly well suited for large wall surfaces where you need treatment and would like to create distinctive architecturally pleasing patterns. Because the 24"x 24" square panels can be installed into a traditional T-bar grid Control Cubes can 'upgrade' the absorption of typical drop ceilings. This can be particularly effective in commercial installations such as noisy offices, call centers and boardrooms that need added sound control. Broadway Control Cubes come in a choice of 2 thicknesses and 3 colors and may be ordered with or without a beveled edge.

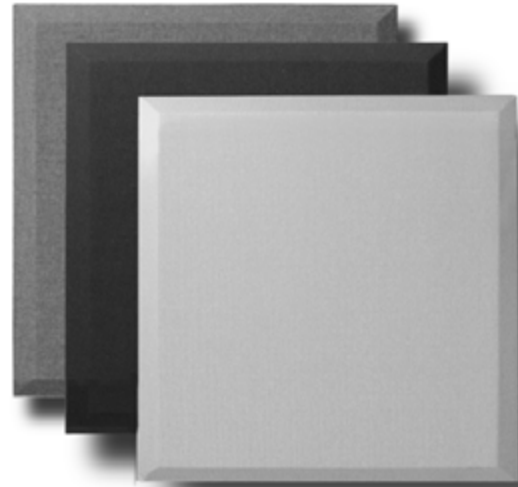

SPECIFICATIONS:

DIMENSIONS	24" x 24" (610mm x 610mm)
PANEL DEPTH	1" (25mm), 2" (51mm)
CORE MATERIAL DENSITY	Formed, semirigid inorganic glass fibers, 6.0 lbs pcf (96 kg/m ³)
FABRIC FACING	Acoustically transparent polyester
BACKING	Sealed with acoustically transparent micro-mesh
EDGE TREATMENT	Sealed and hardened with resin

APPLICATION:

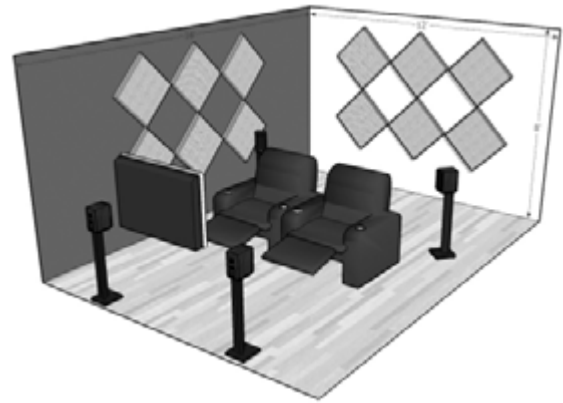

ABSORPTION CHARACTERISTICS:*

PANEL DEPTH	125Hz	250Hz	500Hz	1kHz	2kHz	4kHz	NRC
1" Depth	0.17	0.28	0.81	1.00	1.02	0.95	0.80
2" Depth	0.45	0.83	1.07	1.00	1.01	1.00	1.00

* Testing performed by Riverbank Acoustical Laboratories. The test method conformed explicitly with the requirements of the ASTM Standard Test Method for Sound Absorption and Sound Absorption Coefficients by the Reverberation Room Method: ASTM C 423-02a and E795-05.

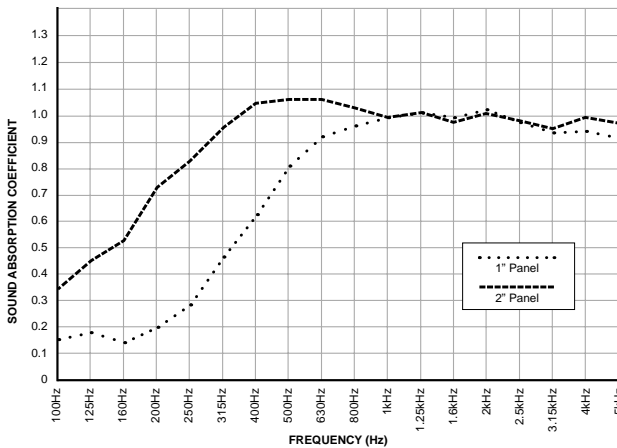

PRODUCT RANGE:

ORDER NO.	COLOR	DEPTH	EDGE	COVERAGE	BOX QTY.
F101-2424-00	Black	1" (25mm)	Square	48 sq/ft (4.46 sq/m)	12
F101-2424-03	Beige				
F101-2424-08	Grey				
F102-2424-00	Black	2" (51mm)	Square	48 sq/ft (4.46 sq/m)	12
F102-2424-03	Beige				
F102-2424-08	Grey				
F122-2424-00	Black	2" (51mm)	Beveled	48 sq/ft (4.46 sq/m)	12
F122-2424-03	Beige				
F122-2424-08	Grey				

FIRE & BURN PERFORMANCE:**

TEST	CLASS	FLAME SPREAD	SMOKE DENSITY
ASTM E 84-05	1 OR A	15 FSI	155 SD
CAN/UL-S102	1 OR A	15 FSC1	155 SD

** Test data provided by Bodycote Materials Testing Inc. This method, designated as ASTM E 84-05, "Standard Method of Test for Surface Burning Characteristics of Building Materials", is used to measure and describe the response of materials, products, or assemblies to heat and flame under controlled conditions, but does not by itself incorporate all factors required for fire-hazard or fire-risk assessment of the materials, products, or assemblies under actual fire condition.

MOUNTING OPTIONS:

SURFACE IMPALER	OFF-SET IMPALER	CORNER IMPALER
F101-1000-00	F101-1001-00	F101-1002-00
24 per box	8 per box	8 per box

24" x 48"
 (610mm x 1219mm)

BROADWAY™ BROADBAND™



Broadway Broadband panels present an attractive, 'easy to install' solution for acoustic treatment when you want maximum control over primary reflections, flutter echo and standing waves. These full size 24"x 48" panels are particularly effective in larger installations and rooms where the reverberant field and echo is excessive. Broadband Absorbers can be 'butted-up' for complete wall coverage and maximum absorption or spread in an array to leave a sense of 'air' or natural ambience. The large panel design also lends itself to other installations: To control bass in studio and home theatre, thicker 2" and 3" Broadband Absorbers are combined with Corner or Offset Impalers to create an air cavity in behind the panel. For general office noise, thinner 1" panels are easily flush mounted on the wall surfaces using Surface impalers to attenuate the reverberant field. These same panels offer an effective 'upgrade' for drop ceilings as the 2 foot by 4 foot panel can fit standard T-bar grid layouts. Broadway Broadband come in choice of 3 thicknesses and 3 colors and may be ordered with our without a beveled edge.

SPECIFICATIONS:

DIMENSIONS	24" x 48" (610mm x 1219mm)
PANEL DEPTH	1" (25mm), 2" (51mm), 3" (76mm)
CORE MATERIAL DENSITY	Formed, semirigid inorganic glass fibers, 6.0 lbs pcf (96 kg/m ³)
FABRIC FACING	Acoustically transparent polyester
BACKING	Sealed with acoustically transparent micro-mesh
EDGE TREATMENT	Sealed and hardened with resin

ABSORPTION CHARACTERISTICS:*

PANEL DEPTH	125Hz	250Hz	500Hz	1kHz	2kHz	4kHz	NRC
1" Depth	0.17	0.28	0.81	1.00	1.02	0.95	0.80
2" Depth	0.45	0.83	1.07	1.00	1.01	1.00	1.00
3" Depth	0.92	0.91	1.00	1.00	1.02	1.03	1.00

* Testing performed by Riverbank Acoustical Laboratories. The test method conformed explicitly with the requirements of the ASTM Standard Test Method for Sound Absorption and Sound Absorption Coefficients by the Reverberation Room Method: ASTM C 423-02 and E795-05.

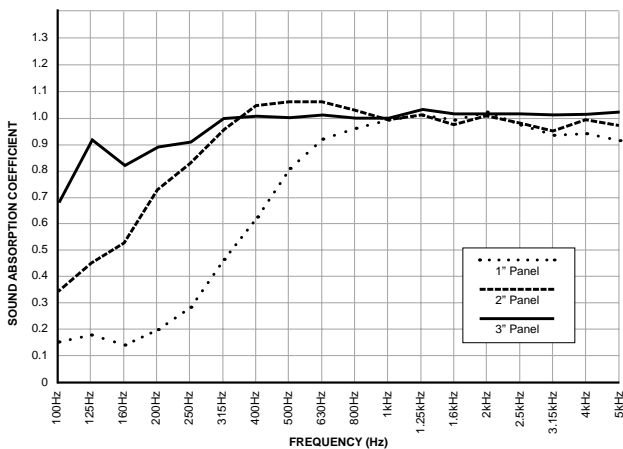
FIRE & BURN PERFORMANCE:**

TEST	CLASS	FLAME SPREAD	SMOKE DENSITY
ASTM E 84-05	1 OR A	15 FSI	155 SD
CAN/UL-S102	1 OR A	15 FSC1	155 SD

** Test data provided by Bocyote Materials Testing Inc. This method, designated as ASTM E 84-05, "Standard Method of Test for Surface Burning Characteristics of Building Materials", is used to measure and describe the response of materials, products, or assemblies to heat and flame under controlled conditions, but does not by itself incorporate all factors required for fire-hazard or fire-risk assessment of the materials, products, or assemblies under actual fire condition.

APPLICATION:

PRODUCT RANGE:

ORDER NO.	COLOR	DEPTH	EDGE	COVERAGE	BOX QTY.
F101-2448-00	Black	1" (25mm)	Square	48 sq/ft (4.46 sq/m)	6
F101-2448-03	Beige				
F101-2448-08	Grey				
F102-2448-00	Black	2" (51mm)	Square	48 sq/ft (4.46 sq/m)	6
F102-2448-03	Beige				
F102-2448-08	Grey				
F122-2448-00	Black	2" (51mm)	Beveled	48 sq/ft (4.46 sq/m)	6
F122-2448-03	Beige				
F122-2448-08	Grey				
F103-2448-00	Black	3" (76mm)	Square	32 sq/ft (2.97 sq/m)	4
F103-2448-03	Beige				
F103-2448-08	Grey				
F123-2448-00	Black	3" (76mm)	Beveled		4
F123-2448-03	Beige				
F123-2448-08	Grey				

MOUNTING OPTIONS:

SURFACE IMPALER	OFF-SET IMPALER	CORNER IMPALER
F101-1000-00	F101-1001-00	F101-1002-00
24 per box	8 per box	8 per box

SURFACE IMPALER™

Primacoustic surface mount impalers are designed to provide the installer with a simple, quick and effective method of mounting Broadway™ fiberglass acoustic panels onto walls without causing serious surface defacement. The surface mount impaler features a series of sharp protruding darts that penetrate the panel to secure it in place during installation. To ensure panels do not get dislodged after installation, applying a dab of construction adhesive to the impaler darts during the mounting process adds a level of security and reduces opportunity for tampering. Impalers are installed using typical sheetrock anchors and screws.

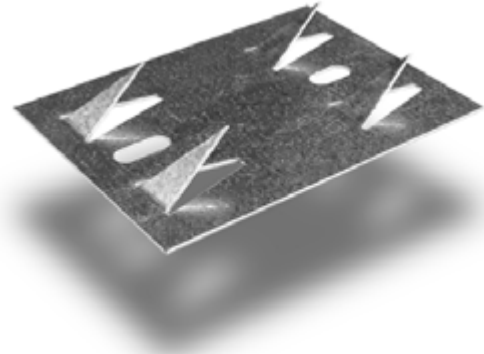

SPECIFICATIONS:

Material	20 gauge galvanized steel
Dimensions	3" (76mm) x 4" (102mm)
Attachment Points	2 (Use an appropriate fastener for wall surface)
Max Load Limit	12 lbs. (5.4 kg.) Dependant on wall fastener
Number per box	16 per box
Order Number	F101-1000-00

RECOMMENDED MINIMUM NUMBER OF IMPALERS PER PANEL:

Order No.	Description	HEIGHT	WIDTH	DEPTH	No. of Impalers Needed*
F101-1212-xx	Scatter Blocks	12" (305mm)	12" (305mm)	1" (25mm)	1
F102-1212-xx	Scatter Blocks	12" (305mm)	12" (305mm)	2" (51mm)	1
F101-2424-xx	Control Cubes	24" (610mm)	24" (610mm)	1" (25mm)	3
F102-2424-xx	Control Cubes	24" (610mm)	24" (610mm)	2" (51mm)	3
F122-2424-xx	Control Cubes	24" (610mm)	24" (610mm)	2" (51mm)	3
F101-1248-xx	Control Columns	12" (305mm)	48" (1219mm)	1" (25mm)	2
F102-1248-xx	Control Columns	12" (305mm)	48" (1219mm)	2" (51mm)	2
F122-1248-xx	Control Columns	12" (305mm)	48" (1219mm)	2" (51mm)	2
F103-1248-xx	Control Columns	12" (305mm)	48" (1219mm)	3" (76mm)	2
F101-2448-xx	Broadband Panels	24" (610mm)	48" (1219mm)	1" (25mm)	4
F102-2448-xx	Broadband Panels	24" (610mm)	48" (1219mm)	2" (51mm)	4
F122-2448-xx	Broadband Panels	24" (610mm)	48" (1219mm)	2" (51mm)	4
F103-2448-xx	Broadband Panels	24" (610mm)	48" (1219mm)	3" (76mm)	4
F123-2448-xx	Broadband Panels	24" (610mm)	48" (1219mm)	3" (76mm)	4

*Primacoustic recommends a certain number of impalers per panel as the minimum required for safe installation based on panel depth and weight. For additional security, you may wish to increase these numbers per panel and also combine with construction adhesive.

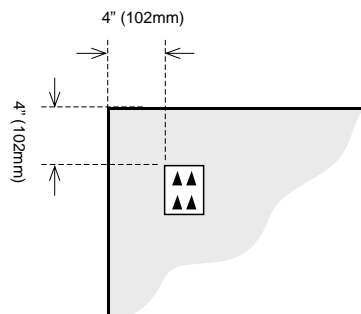
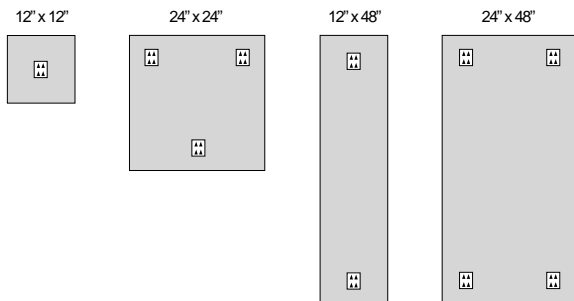

Flush mount impaler clips should be located approximately 4 inches (102mm) or more from the panel edges.

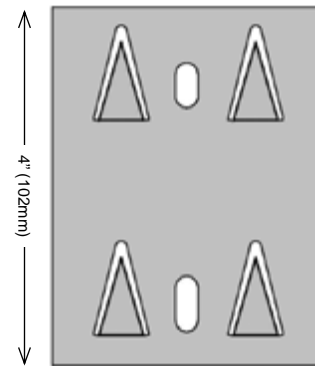
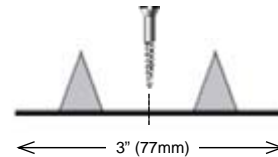

WALL MOUNTING:

Place top edge on set line. Carefully swing bottom edge to meet impaler heads. With the panel resting on the impaler darts, apply in towards wall and downward pressure.

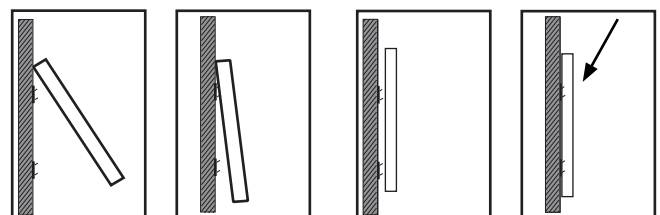

OFFSET IMPALER™

Primacoustic Offset impalers provide the installer with a simple, quick and effective method of mounting Broadway™ fiberglass acoustic panels onto wall surfaces while creating an air cavity behind the panel to increase bass absorption. The Offset impaler features a U-shaped design that elevates the panel from the wall surface by 3.5" making it easy to align with typical 2" x 4" studs. The panel is held in place using a series of sharp protruding darts that penetrate the panel to secure it during installation. To ensure panels do not get dislodged after installation, applying a dab of construction adhesive to the impaler darts during the mounting process adds a level of security and reduces opportunity for tampering. Impalers are installed using typical sheetrock anchors and screws and therefore, will not cause serious surface defacement to the wall.

SPECIFICATIONS:

Material	20 gauge galvanized steel
Dimensions	3" (76mm) x 5" (127mm); Offset = 3.5" (89mm) from wall surface
Attachment Points	4 (Use an appropriate fastener for wall surface)
Max Load Limit	12 lbs. (5.4 kg.) Dependant on wall fastener
Number per box	8 per box
Order Number	F101-1035-00

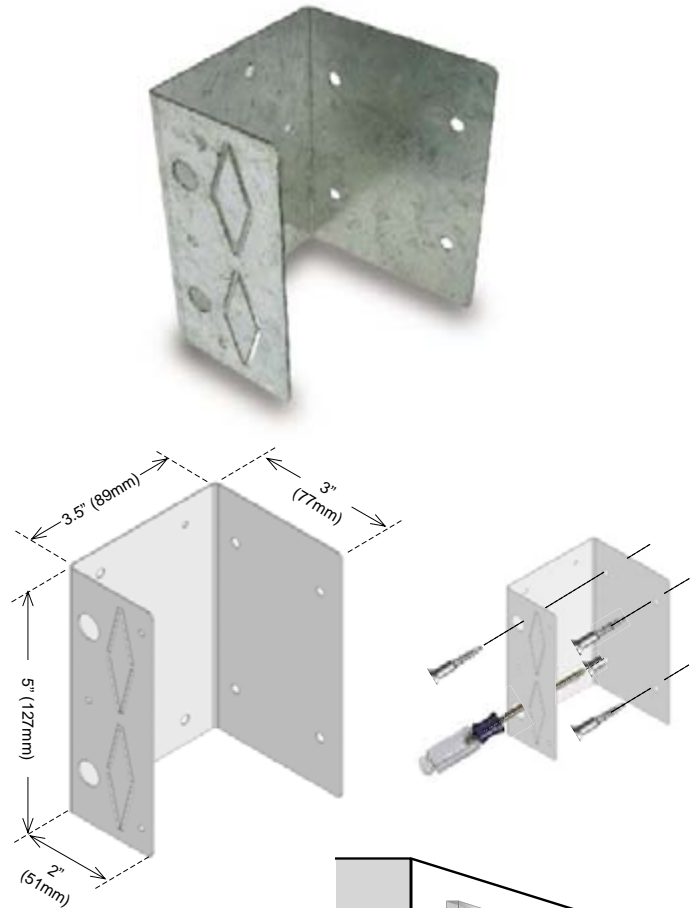

ABSORPTION CHARACTERISTICS:**

Sound absorption data (NRC values) ASTM C423-90a.

Panel Depth	125Hz	250Hz	500Hz	1kHz	2kHz	4kHz	NRC
3" Panel	0.92	0.91	1.00	1.00	1.02	1.03	1.00
With 3.5" offset***	0.83	1.08	1.29	1.22	1.15	1.05	1.20
2" Depth	0.45	0.83	1.07	1.00	1.01	1.00	1.00
with 3.5" Offset***	0.51	1.00	1.32	1.22	1.16	1.09	1.10

** Testing performed by Riverbank Acoustical Laboratories. The test method conformed explicitly with the requirements of the ASTM Standard Test Method for Sound Absorption and Sound Absorption Coefficients by the Reverberation Room Method: ASTM C 423-02a and E795-05. ***Offset mounted to create an air space between the panel and wall.

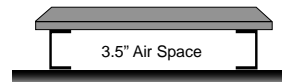

Air space formed using offset impaler clip.

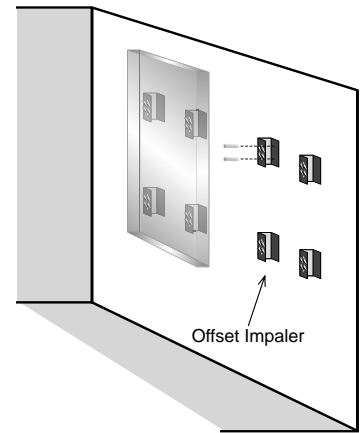

Offset Impaler

Three inch Broadway panels with and without a 3.5" air space.

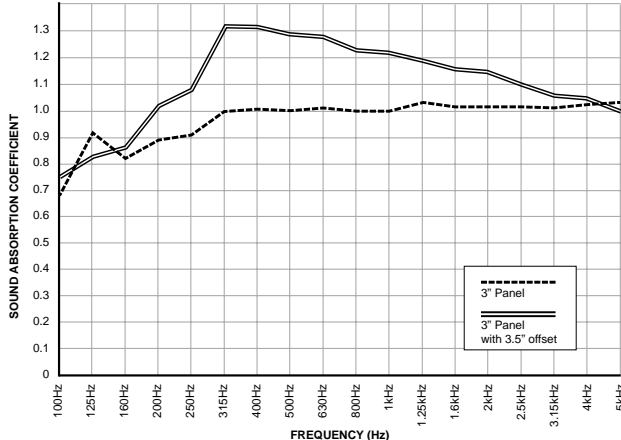

Two inch Broadway panels with and without a 3.5" air space.

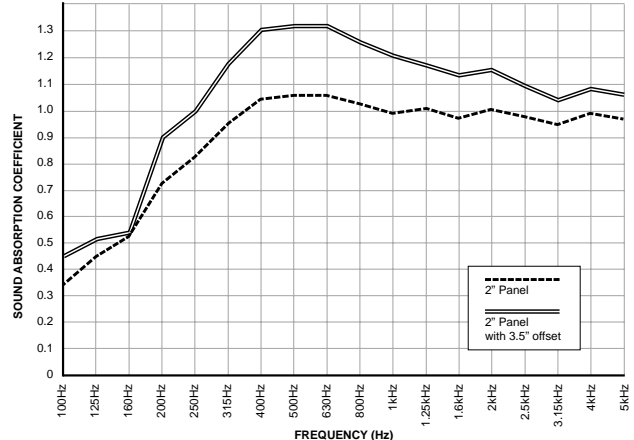

CORNER IMPALER™

Primacoustic Corner impalers are designed to provide the installer with a simple, quick and effective method of mounting Broadway™ fiberglass acoustic panels into corners to create a bass trap. The Corner impaler features a 45° angle design that positions a panel across a typical 90° corner without causing serious defacement of the wall surface. The panel is held in place using a series of sharp protruding darts that penetrate the panel to secure it during installation. To ensure panels do not get dislodged after installation, a dab of construction adhesive may be applied to the impaler darts during the mounting process adding a higher level of security and reducing opportunity for tampering. Impalers are installed using typical sheetrock anchors and screws.

SPECIFICATIONS:

Material	20 gauge galvanized steel
Dimensions	3" (76mm) x 5" (127mm); 45° angle for 90° corners.
Attachment Points	4 x (Use appropriate fastener for wall surface)
Max Load Limit	12 lbs. (5.4 kg.) Dependant on wall fastener
Number per box	8 pieces
Order Number	F101-1001-00

RECOMMENDED NUMBER OF IMPALERS PER PANEL:

Order No.	Description	HEIGHT	WIDTH	DEPTH	No. of Impalers Needed
F102-2448-	Broadband Panels	24" (610mm)	48" (1219mm)	2" (51mm)	4
F122-2448-	Broadband Panels	24" (610mm)	48" (1219mm)	2" (51mm)	4
F103-2448-	Broadband Panels	24" (610mm)	48" (1219mm)	3" (76mm)	4
F123-2448-	Broadband Panels	24" (610mm)	48" (1219mm)	3" (76mm)	4

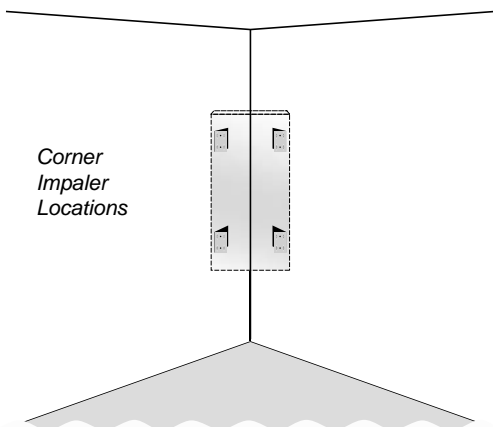
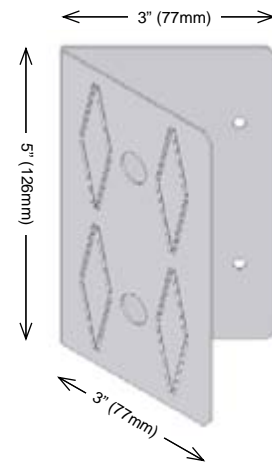

Access hole for screw driver to pass through.

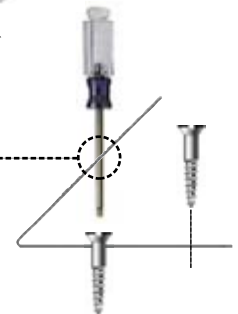

MOUNTING:

- 24" (610mm) wide Broadway panel, space impaler clip 17" (432mm) from corner.

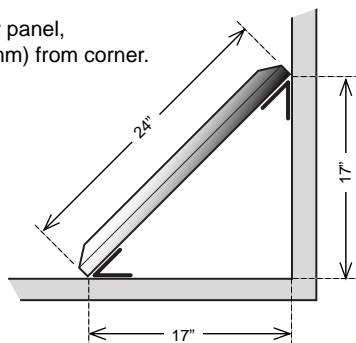

PREPARING IMPALER HEADS:

Impaler darts are bi-directional and are pivoted outward as needed to create left and right Corner impalers.

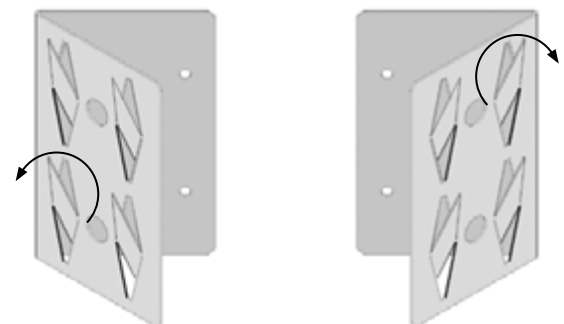

LONDON 12-a™ ROOM KIT

The Broadway London 12-a room kit is designed for rooms that have a footprint of approximately 120 square feet (11 sq./meters). These easy-to-use kits contain everything you need to address room problems such as primary reflections, flutter echo, standing waves and excessive bass. The kit consists of select Broadway acoustic panels that, when installed, follow a variant of the LEDE concept (live-end, dead-end) whereby the source or transmit section of the room has greater dampening while the receive section is sparsely treated in effort to retain natural room ambiance. To help create a natural sounding room two, full size 24" x 48", panels are mounted across 90° room corners to trap bass and balance the absorption between high and low frequencies. In addition to the acoustic panels each London room kit includes the corresponding mounting hardware and instructions for easy installation. Broadway panels are made from high density 6lb per-cubit-foot fiberglass panels for upwards to five (5) times greater absorption than offered by typical low cost 1.3lb foam alternatives. This means that you get more absorption with less panels on the wall while assuring a more even absorption curve throughout the frequency range. The London 12-a room kit is available in three fabric colors.



SPECIFICATIONS:

SURFACE COVERAGE	60 sq/ft (5.6 sq/m)
PANEL SIZES & QUANTITY	Two - 24" x 48" x 2" (beveled edge)
	Eight - 12" x 48" x 2" (beveled edge)
	Twelve - 12" x 12" x 1" (square edge)
MOUNTING IMPALERS	Twenty eight - Surface impaler clips; Eight - Corner impaler clips

ABSORPTION CHARACTERISTICS:

PANEL DEPTH	125Hz	250Hz	500Hz	1kHz	2kHz	4kHz	NRC
1" Depth*	0.17	0.28	0.81	1.00	1.02	0.95	0.80
2" Depth*	0.45	0.83	1.07	1.00	1.01	1.00	1.00
2" Depth (corner mounted**)	0.68	1.2	1.07	1.00	1.01	1.00	1.00

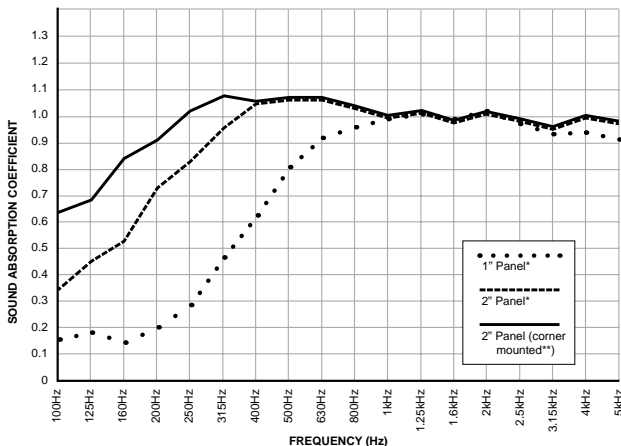
* Testing performed by Riverbank Acoustical Laboratories. The test method conformed explicitly with the requirements of the ASTM Standard Test Method for Sound Absorption and Sound Absorption Coefficients by the Reverberation Room Method: ASTM C 423-02a and E795-05. ** Typical performance based on quarter wavelength calculations.



FIRE & BURN PERFORMANCE:***

TEST	CLASS	FLAME SPREAD	SMOKE DENSITY
ASTM E 84-05	1 OR A	15 FSI	155 SD
CAN/UL-S102	1 OR A	15 FSC1	155 SD

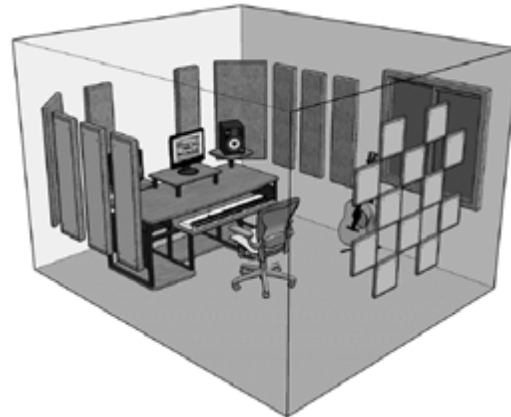
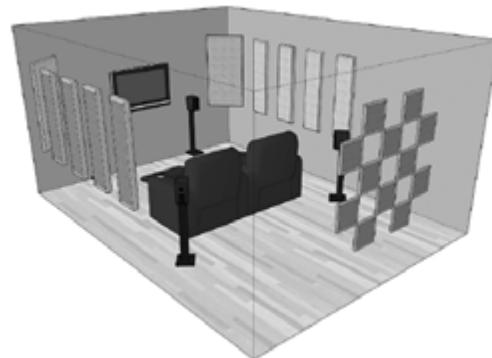
*** Test data provided by Bocyote Materials Testing Inc. This method, designated as ASTM E 84-05, "Standard Method of Test for Surface Burning Characteristics of Building Materials", is used to measure and describe the response of materials, products, or assemblies to heat and flame under controlled conditions, but does not by itself incorporate all factors required for fire-hazard or fire-risk assessment of the materials, products, or assemblies under actual fire condition.

RECORDING STUDIO APPLICATION:

HOME THEATER APPLICATION:

MOUNTING:

Mounting is accomplished with included Primacoustic impaler clips.

SURFACE IMPALER	CORNER IMPALER
	
F101-1000-00	F101-1002-00
28 per kit - mounts the 12" x 12" and 12" x 48" panels	8 per kit - used to corner mount the 24" x 48" panels

RAZORBLADE™ QUADRATIC DIFFUSER

Primacoustic Razorblade is a true quadratic residue diffuser that will effectively break-up standing waves and directional reflections to provide a sense of air and increased space in any room. The Razorblade is constructed using a combination of furniture-grade plywood for durability and high-density fiber board for increased mass and features 15 varying well depths that combine to effectively diffuse directional frequencies above the critical 400Hz region. Offered in an easy to clean black finish, the Razorblade comes fully assembled. Mounting is generally performed using a simple rail below a diffusion cluster to hold the weight and then fixing the top to secure the Razorblades in place. Ideally suited for recording studios, theaters of all sizes and critical listening environments.



SPECIFICATIONS:

Frame Material	Black melamine laminated MDF
Dimensions	24" (610mm) x 48" (1219mm) x 8" (203mm)
Order Number	Z840-2400-00

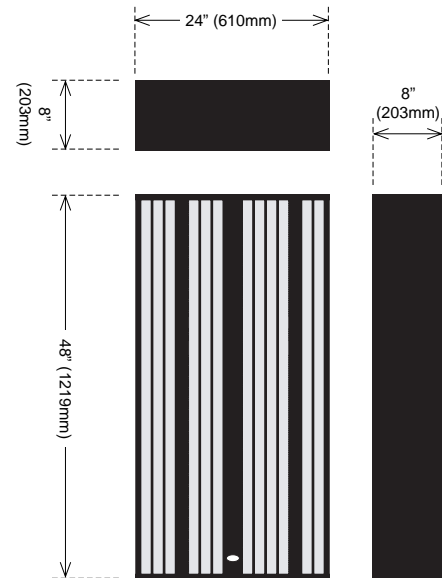

IMPULSE RESPONSE TEST:

Graph-1:

Room without Diffusion

The first spike represents the rooms early, or primary reflections. The second spike indicates the secondary reflections or room ambience. The secondary is a full 10dB louder than the early reflections and most of the energy is bunched up at one point in time showing a peak.

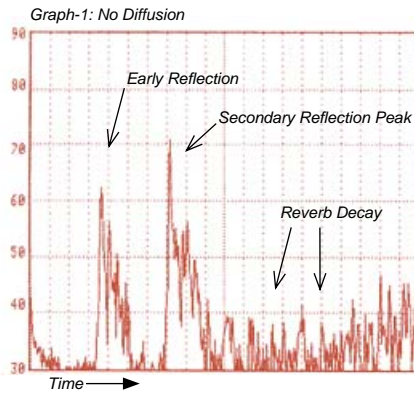

Graph-2:

Room with Diffusion

Diffusion works by dispersing peak acoustic energy and spreading these spikes over a broader time span, creating secondary reflections that decay gradually and evenly. Diffusion is perceived as a natural wash of reverberation.

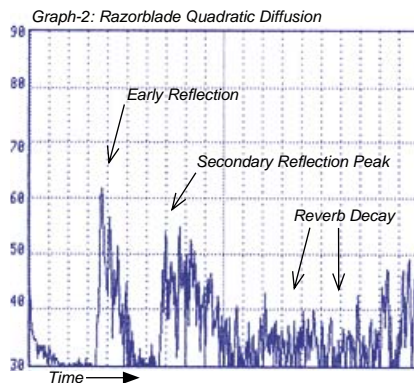

APPLICATION:

Diffusers on the rear wall span the width of the listening position and break up front-to-back waves.

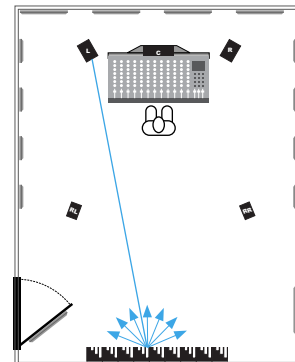

FULLTRAP™

Primacoustic FullTrap is a combination broadband absorber and bass trap that is mounted on a wall surface to control excessive bass in a room. This is achieved by combining three acoustical principles into a single device: to handle mid-range and upper frequencies, a 3" thick front absorptive panel made from 6 lbs. per cubic foot high-density encapsulated fiberglass is employed. Behind the acoustic panel is a stretched diaphragmatic dense-mass membrane that acts as a low frequency resonator to absorb bass down to 75Hz. Behind the membrane, is an air cavity that is created by the wood composite enclosure which serves to further attenuate bass in the troublesome 100Hz region. The FullTrap enclosure is made from MDF wood composite with a black, easy to clean melamine finish and ships flat to save freight. Final assembly is performed on site using a simple household screwdriver, and building a FullTrap takes about 15 minutes from start to finish!

SPECIFICATIONS:

Frame Material	Black melamine laminated MDF
Dimensions	24" (610mm) x 48" (1219mm) x 8" (203mm)
Panel Material	Formed, semirigid inorganic glass fibers; Density 6.0 lbs. pcf. (96 kg/m ³)
Fabric Facing	Acoustically transparent polyester
Diaphragmatic Membrane	Loaded vinyl, 1 lbs. pcf.
Order Number	Z840-1100-xx (xx denotes color code 00=Black; 03= Beige; 08=Grey)

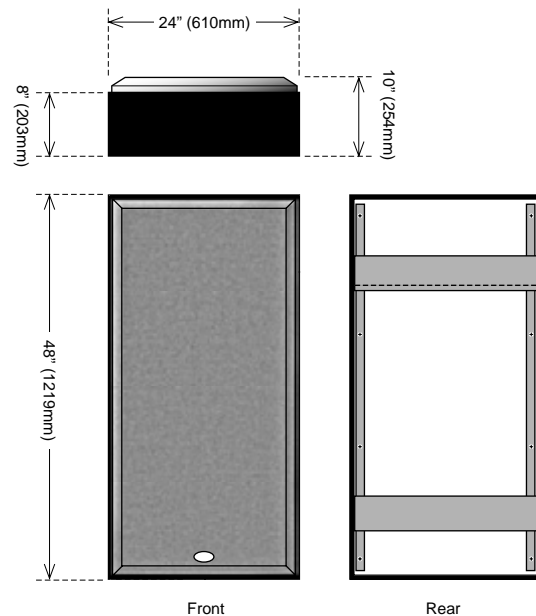
ABSORPTION CHARACTERISTICS*:

Sound absorption data (NRC values).

50Hz	80Hz	125Hz	250Hz	500Hz	1kHz	2kHz	4kHz	5kHz
0.65	1.01	1.17	1.08	1.29	1.22	1.15	1.05	1.00

*Due to the size of the wavelengths and limitations of the testing facilities, low frequency absorption data is based on a combination of Broadway panel test results from Riverbank Acoustical Laboratories and 1/4 wave length calculations.

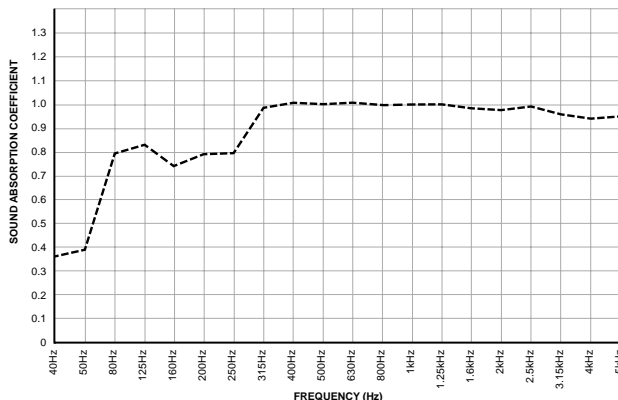
FIRE & BURN PERFORMANCE:

TEST	CLASS	FLAME SPREAD	SMOKE DENSITY
ASTM E 84-05*	1 OR A	15 FSI	155 SD
CAN/UL-S102	1 OR A	15 FSC1	155 SD

Test data provided by Bodycote Materials Testing Inc.

*Fire and burn test data applies to the acoustic panel only and does not include the MDF wood encasement for fire-hazard or fire-risk assessment. Please consult your local building authority and/or insurance underwriter to ensure the product meets local building codes.

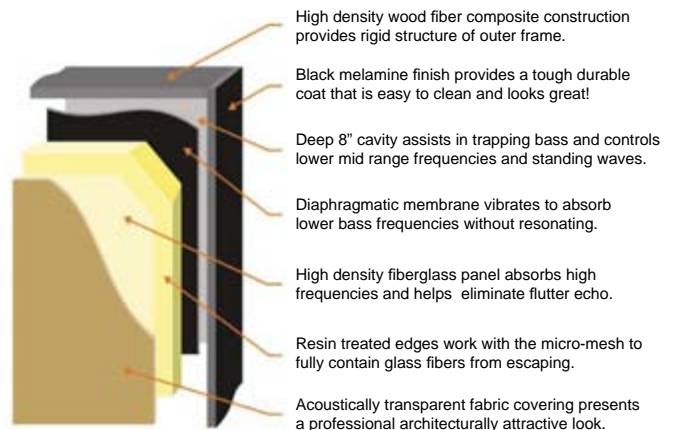

MAXTRAP™

Primacoustic MaxTrap is a combination broadband absorber and bass trap that is corner-mounted to control excessive bass in a room. This is achieved by combining three acoustical principles into a single device: to handle mid-range and upper frequencies, a 3" thick front absorptive panel made from 6 lbs. per cubic foot high-density encapsulated fiberglass is employed. Behind the acoustic panel is a stretched diaphragmatic dense-mass membrane that acts as a low frequency resonator to absorb bass down to 65Hz. Behind the membrane, is an air cavity that is created by the wood composite enclosure which serves to further attenuate bass in the troublesome 100Hz region. The MaxTrap enclosure is made from MDF wood composite with a black, easy to clean melamine finish and ships flat to save freight. Final assembly is performed on site using a simple household screwdriver and building a MaxTrap takes about 15 minutes from start to finish!



SPECIFICATIONS:

Frame Material	Black melamine laminated MDF
Dimensions	24" (610mm) x 48" (1219mm) x 19" (See detail dimensions)
Panel Material	Formed, semirigid inorganic glass fibers: Density 6.0 lbs. pcf. (96 kg/m3)
Fabric Facing	Acoustically transparent polyester
Diaphragmatic Membrane	Loaded vinyl, 1 lbs. pcf.
Order Number	Z840-1110-xx (xx denotes color code 00=Black; 03= Beige; 08=Grey)

ABSORPTION CHARACTERISTICS*:

Sound absorption data (NRC values).

50Hz	80Hz	125Hz	250Hz	500Hz	1kHz	2kHz	4kHz	5kHz
1.29	2.76	1.76	1.26	1.33	1.23	1.19	1.13	1.13

*Due to the size of the wavelengths and limitations of the testing facilities, low frequency absorption test results data from Riverbank Acoustical Laboratories are summarized. For complete details download the actual test result documents from www.primacoustic.com.

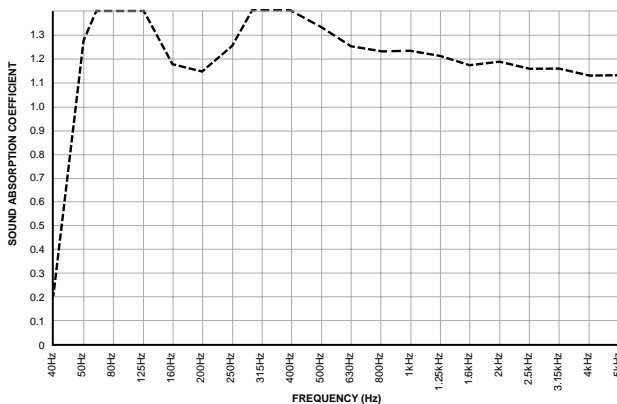

FIRE & BURN PERFORMANCE:

TEST	CLASS	FLAME SPREAD	SMOKE DENSITY
ASTM E 84-05*	1 OR A	15 FSI	155 SD
CAN/UL-S102	1 OR A	15 FSC1	155 SD

Test data provided by Bodycote Materials Testing Inc.

*Fire and burn test data applies to the acoustic panel only and does not include the MDF wood encasement for fire-hazard or fire-risk assessment. Please consult your local building authority and/or insurance underwriter to ensure the product meets local building codes.

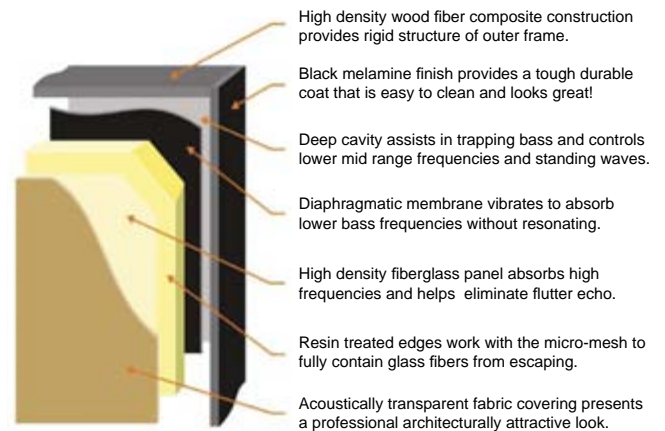
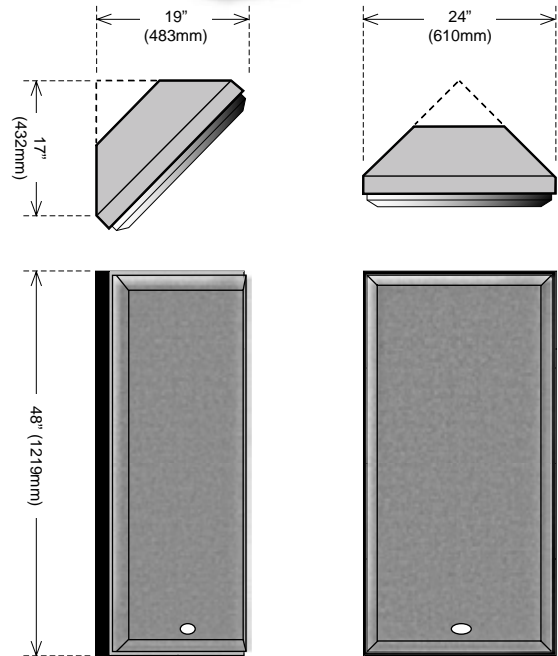

CUMULUS™ CORNER TRAP

The Primacoustic Cumulus is a triangular broadband acoustic corner trap that effectively absorbs sound energy from 125Hz and up. Designed to fit in corners where the walls and ceiling meet, the Cumulus takes advantage of the natural propagation of sound that occurs in all rooms. Sound waves follow the wall and ceiling planes and accumulate in the corners, a well known hot spot in small rooms. The Cumulus is amazingly compact yet, when in place, creates a 12" deep cavity behind the panel that increases the bass absorption characteristics. Mounting Cumulus traps in a room will generally yield a significant reduction in the problematic low-mid (100Hz - 200Hz) region while leaving the architectural design of the room virtually intact. Invisible mounting is achieved using spring-tensioned cleats and a single eye-screw. Mounting literally takes minutes and because of the reverse beveled edges Cumulus traps flush mount 'seamlessly' into the room esthetics. Sold in pairs.

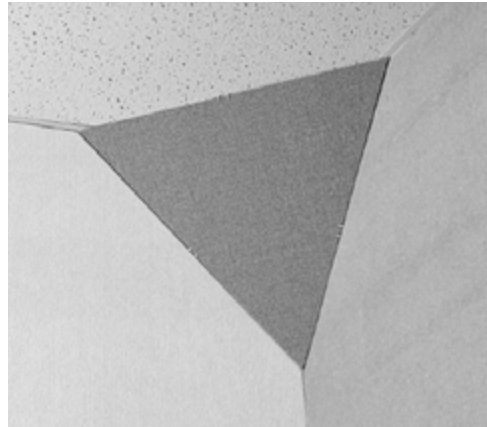

SPECIFICATIONS:

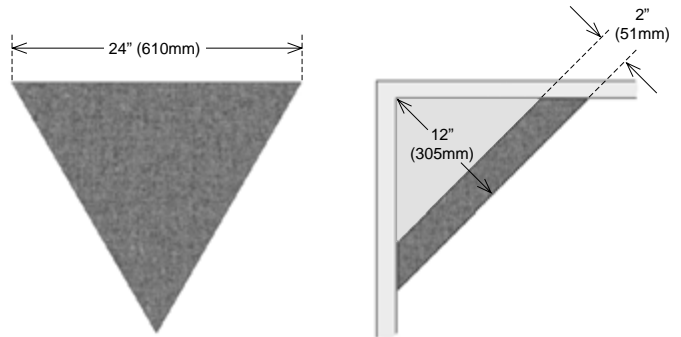
DIMENSIONS	24" x 24" x 24" (610mm x 610mm x 610mm)
PANEL DEPTH	2" (51mm)
CORE MATERIAL DENSITY	Formed, semirigid inorganic glass fibers, 6.0 lbs pcf (96 kg/m ³)
FABRIC FACING	Acoustically transparent polyester
BACKING	Sealed with acoustically transparent micro-mesh
EDGE TREATMENT	Reverse bevel edge. Sealed and hardened with resin

ABSORPTION CHARACTERISTICS:*

PANEL DEPTH	125Hz	250Hz	500Hz	1kHz	2kHz	4kHz	NRC
2" Depth	0.45	0.83	1.07	1.00	1.01	1.00	1.00

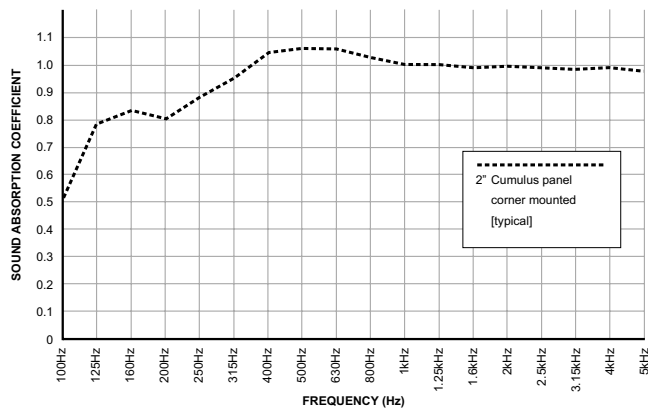
* Testing performed by Riverbank Acoustical Laboratories. The test method conformed explicitly with the requirements of the ASTM Standard Test Method for Sound Absorption and Sound Absorption Coefficients by the Reverberation Room Method: ASTM C 423-02a and E795-05.

APPLICATION:

MOUNTING:

Mounting is accomplished with spring tensioned cleats and a single eye-screw.

FIRE & BURN PERFORMANCE:**

TEST	CLASS	FLAME SPREAD	SMOKE DENSITY
ASTM E 84-05	1 OR A	15 FSI	155 SD
CAN/UL-S102	1 OR A	15 FSC1	155 SD

** Test data provided by Bodycote Materials Testing Inc. This method, designated as ASTM E 84-05, "Standard Method of Test for Surface Burning Characteristics of Building Materials", is used to measure and describe the response of materials, products, or assemblies to heat and flame under controlled conditions, but does not by itself incorporate all factors required for fire-hazard or fire-risk assessment of the materials, products, or assemblies under actual fire condition.

STRATUS™ CLOUD KIT

The Stratus Cloud kit consists of a Primacoustic 24" x 48" Broadway panel and aluminium hardware for overhead suspension. The absorptive panel is made from 6 lbs. per cubic foot high-density encapsulated fiberglass. The aluminium hardware clamps onto the panel sides and provides four points to hang from. The science is based on thermo-dynamic energy transfer, where sound penetrating the Stratus Cloud causes the glass fibers to vibrate which in turn, converts the acoustic energy into heat. The Stratus Cloud Kit ships flat and final assemble is performed the end user. A screwdriver is the only tool required for assembly. Each kit contains the absorptive panel, aluminium side clamps and cross-bars. Assembly takes about 15 minutes from start to finish!

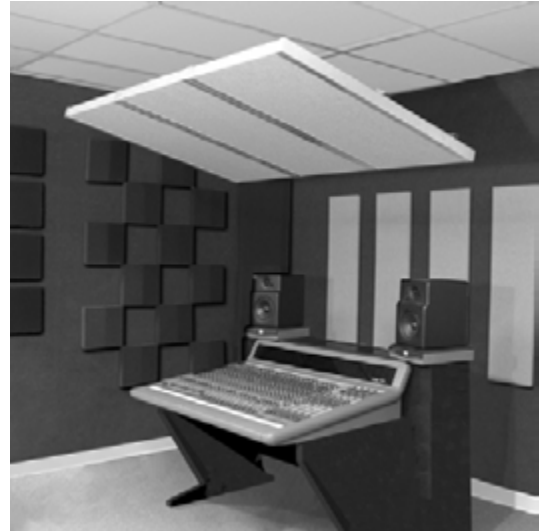

Photo shows three Stratus Cloud Kits above mixing console.

SPECIFICATIONS:

Frame Material	Formed 16 gauge aluminium
Dimensions	24" (610mm) x 48" (1219mm) x 2" (51mm)
Panel Material	Formed, semirigid inorganic glass fibers; Density 6.0 lbs pcf (96 kg/m ³)
Fabric Facing	Acoustically transparent polyester

ABSORPTION CHARACTERISTICS:**

Sound absorption data (NRC values) ASTM C423-90a.

Panel Depth	125Hz	250Hz	500Hz	1kHz	2kHz	4kHz	NRC
2" Depth	0.45	0.83	1.07	1.00	1.01	1.00	1.00
2" Offset 2" ***	0.51	0.90	1.17	1.12	1.12	1.08	1.10

** Testing performed by Riverbank Acoustical Laboratories. The test method conformed explicitly with the requirements of the ASTM Standard Test Method for Sound Absorption and Sound Absorption Coefficients by the Reverberation Room Method: ASTM C 423-02a and E795-05. ***Offset mounted to create an air space between the panel and ceiling.

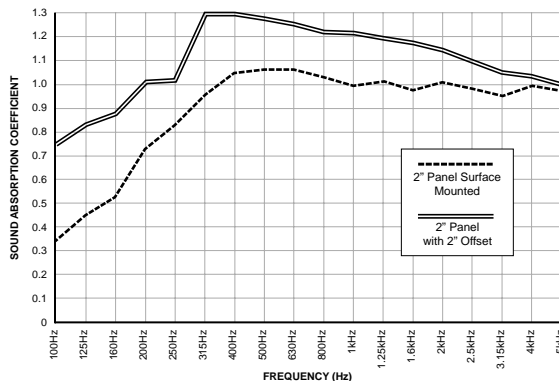

FIRE & BURN PERFORMANCE:

TEST	CLASS	FLAME SPREAD	SMOKE DENSITY
ASTM E 84-05*	1 OR A	15 FSI	155 SD
CAN/UL-S102	1 OR A	15 FSC1	155 SD

Test data provided by Bodycote Materials Testing Inc.

*This method, designated as ASTM E 84-05, "Standard Method of Test for Surface Burning Characteristics of Building Materials", is used to measure and describe the response of materials, products, or assemblies to heat and flame under controlled conditions, but does not by itself incorporate all factors required for fire-hazard or fire-risk assessment of the materials, products, or assemblies under actual fire condition.

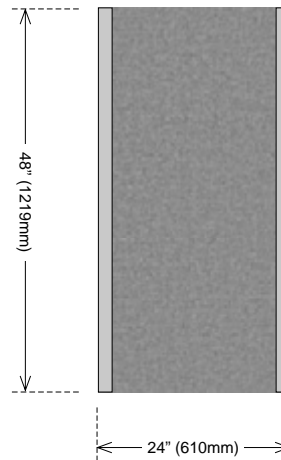
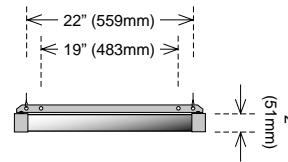

KIT COMPONENTS:

- 24 x 48 Broadway panel
- Two aluminum side clamps
- Two cross bars
- Assembly screws
- Bracket to link units together



MOUNTING:

Hanging is achieved with four eyelets in the cross bar members. Use chain, wire-rope or bailing wire. We recommend the Stratus be mounted with a four point dead-hang. Extra eyelets can be used for anti-way or safety lines.

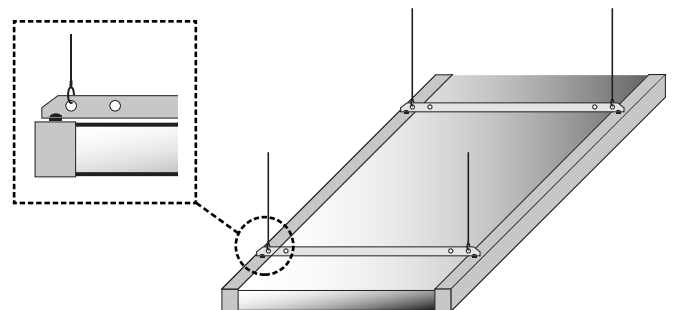

G-TRAP™

Primacoustic G-Trap is a stand-alone combination broadband absorber and bass trap that helps control excessive bass in a room while acting as a sound barrier gobo (go-between) in the studio. Sound absorption is achieved by combining three acoustical principles into a single device: to handle mid-range and upper frequencies, two 2" thick absorptive panels are mounted on the front and back. These are made from 6 lbs. per cubic foot high-density encapsulated fiberglass. Between the acoustic panels is a rigid membrane that acts as a sound block for high frequencies and as an impedance barrier for low frequencies. An air cavity is created by the plywood enclosure which serves to further attenuate bass in the troublesome 100Hz region. The G-Trap enclosure is made from Baltic birch plywood with an easy to clean natural wood finish. The G-trap ships flat to save freight and it takes about 15 minutes to assemble!

SPECIFICATIONS:

Frame Material	Baltic Birch Plywood with dovetail corner joints
Dimensions	36" (914mm) x 24" (609mm) x 10" (254mm)
Panel Material	Formed, semirigid inorganic glass fibers; Density 6.0 lbs pcf (96 kg/m ³)
Fabric Facing	Acoustically transparent polyester
Ridgid Membrane	1/4" hardboard.
Order Number	Z840-1120-xx (xx denotes color code 00=Black; 03= Beige; 08=Grey)

ABSORPTION CHARACTERISTICS*:

Sound absorption data (NRC values).

50Hz	80Hz	125Hz	250Hz	500Hz	1kHz	2kHz	4kHz	5kHz
0.95	1.10	1.20	1.08	1.29	1.22	1.15	1.05	1.00

*Theoretical absorption based on Broadway panel test results and 1/4 wavelength calculation.

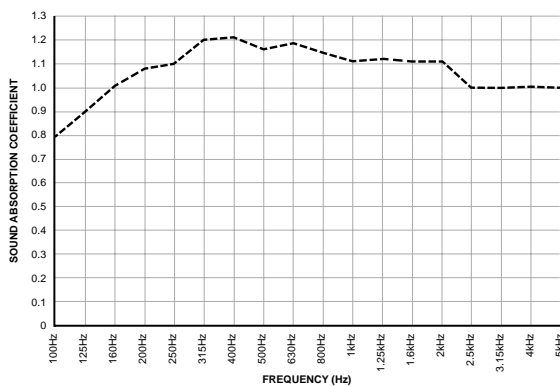
FIRE & BURN PERFORMANCE:

TEST	CLASS	FLAME SPREAD	SMOKE DENSITY
ASTM E 84-05*	1 OR A	15 FSI	155 SD
CAN/UL-S102	1 OR A	15 FSC1	155 SD

Test data provided by Bodycote Materials Testing Inc.

*Fire and burn test data applies to the acoustic panel only and does not include the plywood encasement for fire-hazard or fire-risk assessment. Please consult your local building authority and/or insurance underwriter to ensure the product meets local building codes.

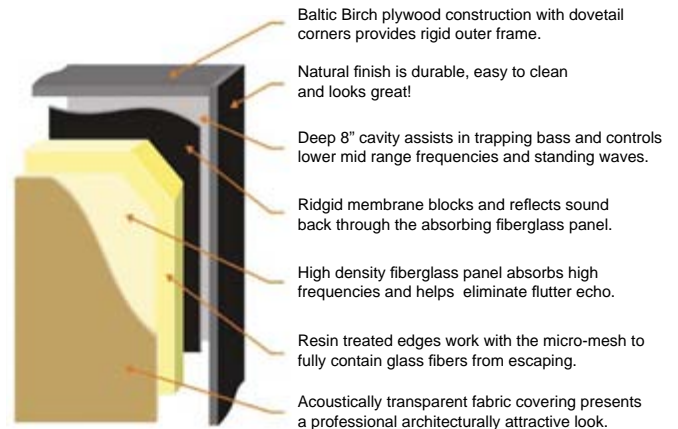
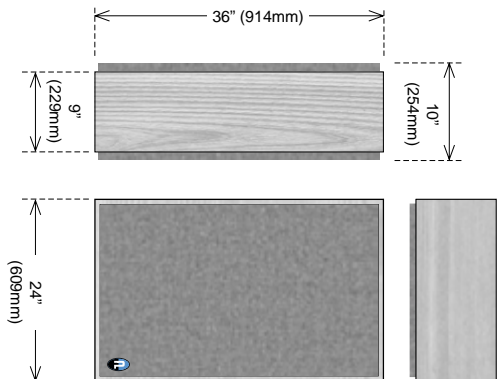
APPLICATION:

G-Trap shown as go-between to isolate drums.

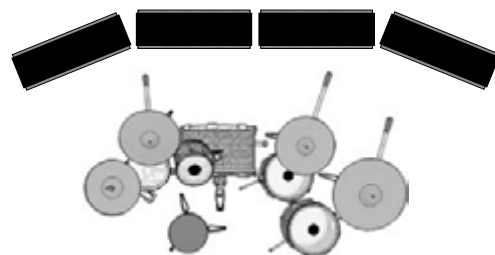

FREEPORT™ GOBO

Freeport is a flexible acoustical absorber that features a 24" x 48" panel section of 3" thick Primacoustic Z-Foam, a high-density open-cell acoustical foam, for maximum absorption in the critical mid and upper bands. The foam component is embedded with a fire retardant to meet the California 117 code, making the Freeport safe for use anywhere. At approximately 6ft tall, Freeport is suited to fit behind speakers, around a mix position, or as a gobo to reduce splash from instruments when recording. For critical recording jobs like voice-overs and sampling Freeports gobos create a quiet, reflection-free zone. This flexibility makes Freeport a must-have for any studio. Unlike other portable systems that use wobbly mic stands as their base, Freeport features an unbreakable integral frame and sturdy base made from rugged PVC tubing that's easy to assemble and sets up in minutes. The internal frame may be permanently glued together or assembled on the spot, then disassembled for storage in it's box.

SPECIFICATIONS:

Panel Dimensions	24" (607mm) x 48" (1219mm) x 3" (76mm)
Over-all Dimensions	24" (607mm) x 70" (1778mm) x 3.25" (82.55mm)
Panel Material	3" High-density open cell acoustic foam; Density 1.6 lbs pcf, California C-117 fire rating for polyurethane foam
Frame Material	PVC tubing
Order Number	Z830-0020-00 (sold in pairs)

APPLICATIONS:

Mixing and recording application for Freeport XT.

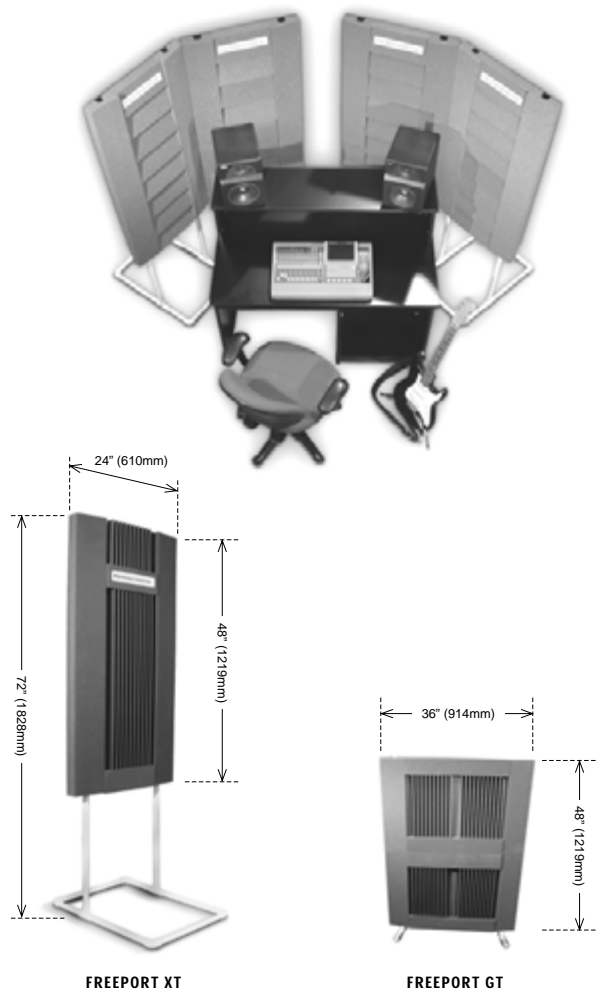

FREEPORT™ GT GOBO

Following the same frame and panel design as the XT, the Freeport GT is a stackable gobo for instrument and amplifier applications. When stacked the over-all height of the GT is 48" (1219mm).

Panel Dimensions	24" (607mm) x 36" (914mm) x 3" (76mm)
Over-all Dimensions	24" (607) x 36" (914mm) x 3.25" (82.55mm)
Panel Material	3" High-density open cell acoustic foam; Density 1.6 lbs pcf, California C-117 fire rating for polyurethane foam
Frame Material	PVC tubing
Order Number	Z830-0030-00 (sold in pairs)

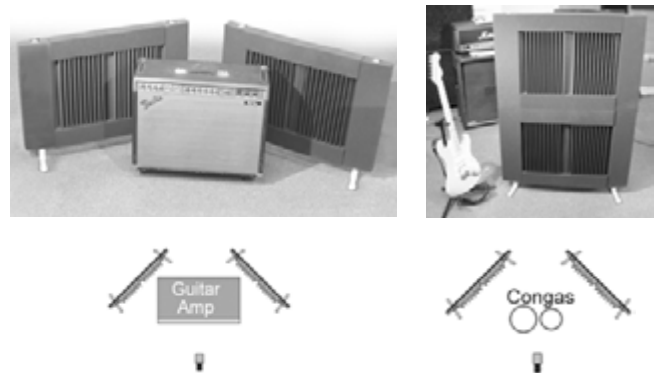
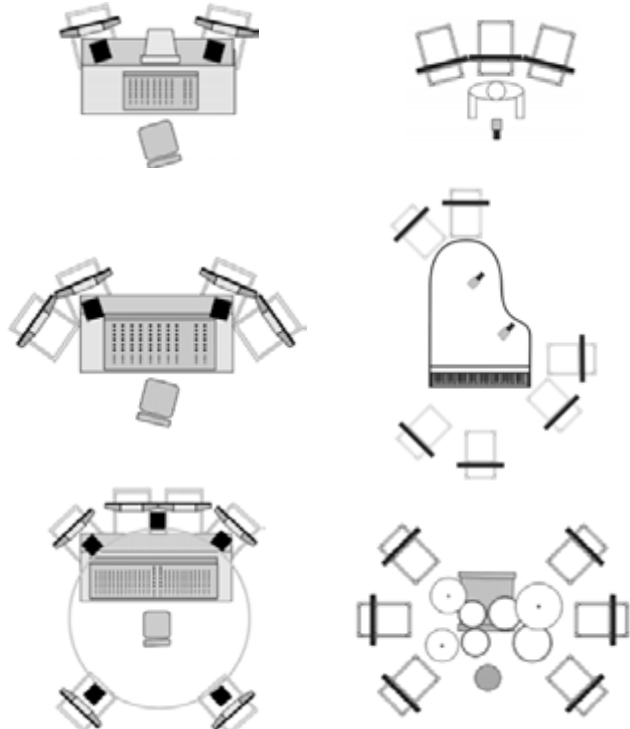

RECOIL STABILIZER™

Patent applied for.

Primacoustic Recoil Stabilizers are a near field reference monitor platform designed to decouple the loudspeaker from the supporting shelf while adding mass to stabilize the speaker from the backward recoil caused by the low frequency driver motion. The Recoil Stabilizer is made from three components: a high-density urethane foam base that acts as an isolator to eliminate resonant frequencies from traveling from the speaker to the shelf, a heavy laser-cut steel base that acts as both the platform for the speaker and as the stabilizing counter-force, and thin a non-slip neoprene surface that is used to hold the speaker securely in place. The Recoil Stabilizer works by simply mounting it beneath the speaker. A range of sizes are available to adapt to various speakers and these may be ordered in horizontal or down-fire angles to aim the loudspeakers as needed.

SPECIFICATIONS:

Deck	1/4" steel, black powder coated with 1/8" Neoprene pad
Base	High density polyurethane foam
Number per box	1
Weight	RX5 - 5.75 lbs. (2.6 kg.); RX7 - 10.8 lbs. (4.9 kg.); RX9 - 12.5 lbs. (5.7 kg.); RX12 - 22 lbs. (10 kg.); RX17 22 lbs. (10 kg.); RX20 - 36 lbs. (16.3 kg.)

DECK DIMENSIONS:

Order No.	Description	WIDTH	DEPTH	HEIGHT	Load Limit
Z860-1505	RX5-HF	7.5" (190.5mm)	9.5" (241mm)	1.87" (47.5mm)	32 lbs.
Z860-1505-05	RX5-DF (5° down angle)	7.5" (190.5mm)	9.5" (241mm)	1.87" (47.5mm)	32 lbs.
Z860-1505-10	RX5-UF (10° up angle)	7.5" (190.5mm)	9.5" (241mm)	1.87" (47.5mm)	32 lbs.
Z860-1507	RX7-HF	10.375" (263mm)	13" (330mm)	2.62" (66.5mm)	44 lbs.
Z860-1507-05	RX7-DF (5° down angle)	10.375" (263mm)	13" (330mm)	2.62" (66.5mm)	44 lbs.
Z860-1509	RX9-HF	15" (381mm)	11" (279mm)	2.62" (66.5mm)	50 lbs.
Z860-1509-05	RX9-DF (5° down angle)	15" (381mm)	11" (279mm)	2.62" (66.5mm)	50 lbs.
Z860-1512	RX12-HF	20" (508mm)	13" (330mm)	2.62" (66.5mm)	88 lbs.
Z860-1512-05	RX12-DF (5° down angle)	20" (508mm)	13" (330mm)	2.62" (66.5mm)	88 lbs.
Z860-1517	RX17	17" (432mm)	17" (432mm)	2.62" (66.5mm)	88 lbs.
Z860-1520	RX20	20" (508mm)	22" (559mm)	2.62" (66.5mm)	144 lbs.

STUDIO MONITOR REFERENCE:

Monitor	Recoil	Monitor	Recoil	Monitor	Recoil
ADAM Audio		Genelec		Mackie	
A7	RX5	1029A	RX5	HR624	RX9
ANF10	RX5	1030A	RX7	HR626	RX7
P11A	RX7	1031A	RX7	HR824	RX7
P22A	RX7	1032A	RX9	Meyer Sound	
P33A	RX9	8020A	RX5	HD 1	RX12
S1A	RX5*	8030A	RX7	M&K Professional	
S2A	RX7	8040A	RX7	MPS-1501	RX5
S2.5A	RX7	8050A	RX7*	MPS-1601	RX5*
S3A	RX9	JBL		MPS-1611	RX7
Blue Sky		LSR6325P-1	RX5	MPS-2510	RX7*
EXO	RX5	LSR6328P	RX9	PMC	
MediaDesk SAT	RX5	LSR4326P	RX7	DB1S-A	RX5
SAT 12	RX12	LSR4328P	RX7	TB2S-A	RX7
SAT 5 MKII	RX5*	Klein & Hummel		Samson	
SAT 6.5 MKII	RX7	O 110	RX5	Resolv A8	RX7
Digidesign		O 300	RX9	Resolv A6	RX7
RM1	RX7	O 410	RX12	Tannoy	
RM2	RX7*	KRK		Reveal 5	RX5*
Dynaudio		RP5	RX5	Reveal 6D	RX7
BM5A	RX7	RP6	RX7	Reveal 66	RX9*
BM6A	RX7	RP8	RX7	Reveal 8D	RX7*
BM15A	RX9	VXT4	RX5	Precision 6	RX7
AIR 6	RX7*	VXT6	RX7	Precision 8	RX7*
AIR 15	RX7*	VXT8	RX9	System 600	RX7
AIR 20	RX9*	E8B	RX9*	System 800	RX7*
Event		V4	RX5	Yamaha	
Studio Precision 6	RX7	V6	RX7	MSP3	RX5
Studio Precision 8	RX9	V8	RX7*	MSP7	RX7
TR6	RX7	M-Audio		MSP10	RX7
TR8	RX7	EX66	RX5*	HS 50M	RX5
Fostex		BX5a	RX5	HS 80M	RX7*
PM0.5 MKII	RX5*	BX8a	RX7*	NS-10	RX5*
PM1 MKII	RX7	DX4	RX5	NS-10 (sidemount)	RX9
PM2 MKII	RX7				

*Deck is undersized in one dimension by less than 1".

